

Thermowell with flange (fabricated) Tantalum cover or wetted parts special material Model TW40 (version TW40-E, TW40-D)

WIKA data sheet TW 95.41

Applications

- Chemical industry, process technology, equipment manufacturing
- For high chemical demands
- For low and medium process loads

Special features

- Good price/performance ratio
- Wetted parts made of special material
- Non-wetted parts (flange, connection components) from stainless steel
- Version TW40-D: Thermowell welded to one unit
Version TW40-E: Tantalum cover exchangeable

Description

Each thermowell is an important component of any temperature measuring location. It is used to separate the process from the surrounding area, thus protecting the environment and operating personnel and keeps aggressive media, high pressures and flow rates from the temperature probe itself and thereby enables the thermometer to be exchanged during operation.

Based on the almost limitless application possibilities, there are a large number of variants, such as thermowell designs or materials. The type of process connection and the basic method of manufacture are important design differentiation criteria. A basic differentiation can be made between threaded and weld-in thermowells, and those with flange connections.

Furthermore, one can differentiate between fabricated and solid-machined thermowells. Fabricated thermowells are constructed from a tube, that is closed at the tip by a welded solid tip. Solid-machined thermowells are manufactured from solid bar stock.



Fig. left: Thermowell with tantalum cover, version TW40-E

Fig. right: Thermowell with washer disc for special material, version TW40-D

The TW40 series of fabricated thermowells with flange connection are suitable for use with numerous electrical and mechanical thermometers from WIKA.

Due to their special design on the basis of DIN 43772, these thermowells, through their use of highly corrosion-resistant materials, are suitable for use for low and medium mechanical process-side loading in the chemical industry, process technology and equipment manufacturing.

Standard version

Thermowell material of wetted parts

Hastelloy C4 (2.4610), Hastelloy C276 (2.4819),
Monel 400 (2.4360), titanium grade 2 (3.7035) ¹⁾, tantalum

Flange disc

per EN 1092-1 with sealing face form B1
per DIN 2527 with sealing face form C per DIN 2526
per ASME B16.5 with sealing face form RF
(smooth sealing face with tantalum)

Nominal width

per EN 1092-1, DIN 2527: DN 25, DN 40, DN 50
per ASME: 1", 1 1/2", 2"

Pressure rating

per EN 1092-1, DIN 2527: PN 16 ... 40
per ASME: 150 lbs, 300 lbs, 600 lbs

Connection to thermometer

M24 x 1.5 rotatable or G 1/2, 1/2 NPT female

Pipe

Ø 13.7 x 2.2 mm

Bore size

Ø 9.3 mm

Tantalum cover, bore size

12 x 0.4 mm for bore size 7 mm
16 x 0.4 mm for bore size 9 mm
13 x 0.4 mm for bore size 6.1 mm

Insertion length U₁

To customer specification

Overall length L

Insertion length U₁ ²⁾ + 80 mm

Max. process temperature, process pressure

Depending on

- Thermowell design
 - Dimensions
 - Material
 - Flange pressure rating
- Process conditions
 - Flow rate
 - Medium density

1) For titanium grade 2 (3.7035) material, the flange with its connection components is designed to be a loose pressure flange

2) For versions with tantalum cover, the insertion length U₁ will be longer by up to 3 mm

Options

- Other dimensions and materials
- Female thread
- Quality certificates

For further information, see Technical information IN 00.15
"Strength calculation for thermowells".

Dimensions in mm

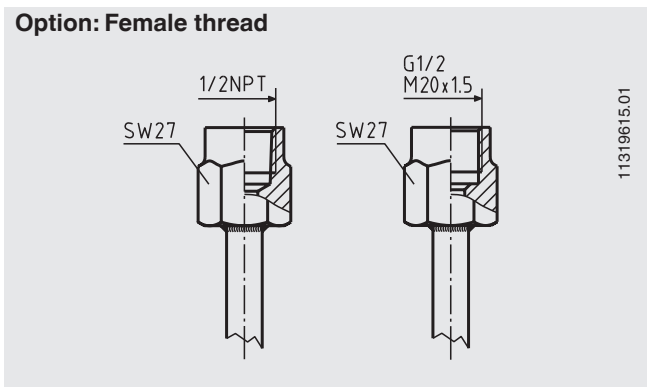
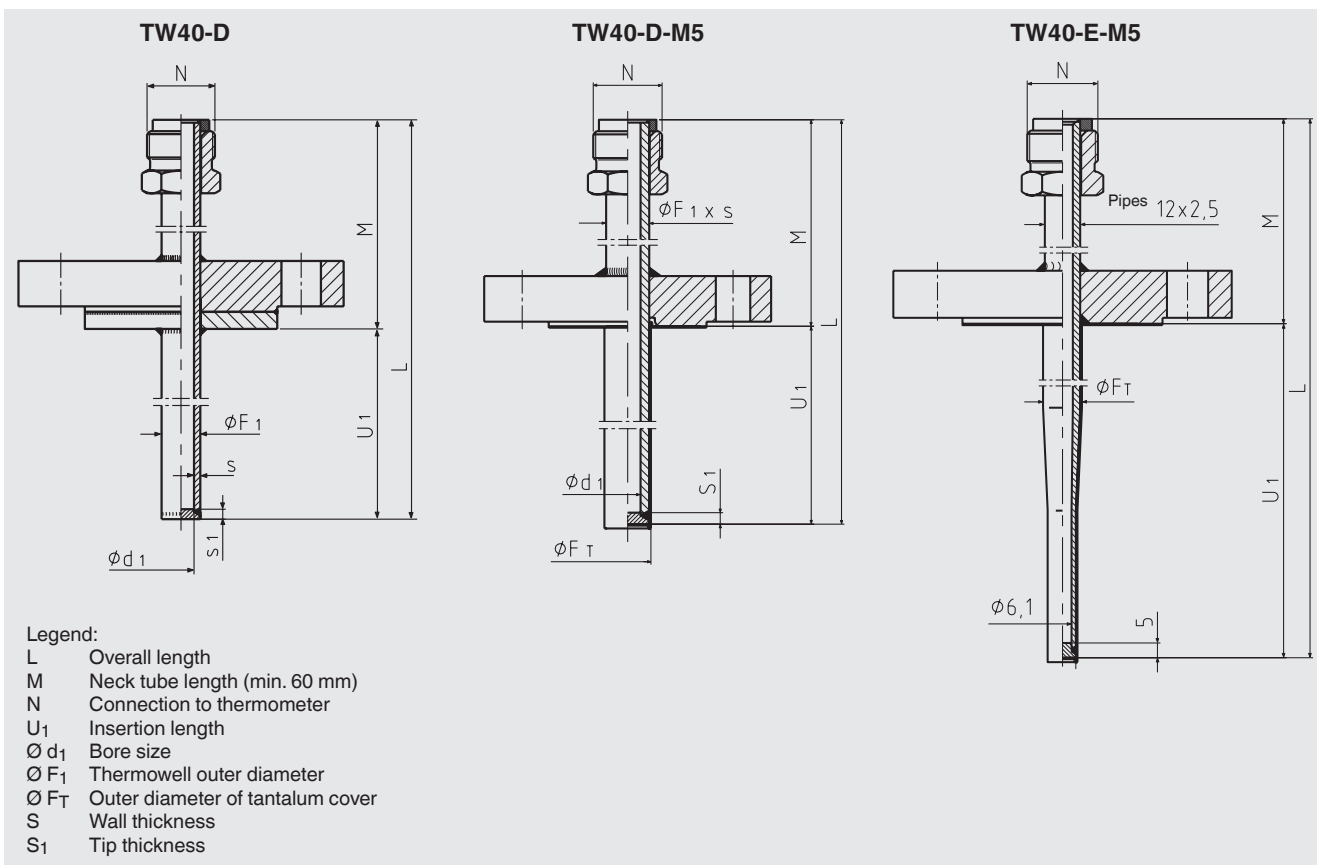

Model TW40-D

Dimensions in mm					Weight in kg	
					Flange DN 25	PN 16 ... 40
N	Ø F ₁	S	S ₁	M	U ₁ = 100 mm	U ₁ = 500 mm
M24 x 1.5	13.7	2.2	3.5	80	1.50	1.90
G ½	13.7	2.2	3.5	80	1.50	1.90
½ NPT	13.7	2.2	3.5	80	1.50	1.90

Additional weight with other flanges		
DN 40	PN 16 ... 40	+0.76 kg
DN 50	PN 16 ... 40	+1.63 kg
1"	150 lbs	-0.46 kg
	300 lbs	+0.04 kg
	600 lbs	+0.22 kg
1 ½"	150 lbs	+0.22 kg
	300 lbs	+1.34 kg
	600 lbs	+1.85 kg

Model TW40-D-M5 (tantalum)

Dimensions in mm					
N	Ø F _T	Ø d ₁	Ø F ₁ x S	S ₁	M
M24 x 1.5	12 x 0.4	7	11 x 2	2.5	80
	16 x 0.4	9	15 x 3	3.5	80
	13 x 0.4	6.1	12 x 2.5	5	82

Suitable stem lengths (dial thermometers)

Connection type	Stem length l ₁
S, 3, 4 or 5	l ₁ = L - 10 mm [0.4 in] or. l ₁ = U ₁ + M - 10 mm [0.4 in]
2	l ₁ = L - 30 mm [1.2 in] or. l ₁ = U ₁ + M - 30 mm [1.2 in]

Sealing face roughness

Flange standard		AARH in µinch	Ra in µm	Rz in µm
ASME B16.5	Stock finish	125 ... 250	3.2 ... 6.3	-
	Smooth finish	< 125	< 3.2	-
EN 1092-1	Form B1	-	3.2 ... 12.5	12.5 ... 50
	Form B2	-	0.8 ... 3.2	3.2 ... 12.5
DIN 2527	Form C	-	-	40 ... 160
	Form E	-	-	< 16

Ordering information

Model / Thermowell form / Pipe dimensions / Nominal width DN / Pressure rating PN / Sealing face / Connection to thermometer / Insertion length U₁ / Overall length L / Thermowell material / Assembly with thermometer / Certificates / Options

© 12/2007 WIKA Alexander Wiegand SE & Co. KG, all rights reserved.
The specifications given in this document represent the state of engineering at the time of publishing.
We reserve the right to make modifications to the specifications and materials.